

kmt

PRODUKTIONS+
MONTAGETECHNIK

Presses

Orbital riveters

Small conveyors

Assembly systems

Multiple spindle heads

Rotary indexing tables

Workpiece carriers

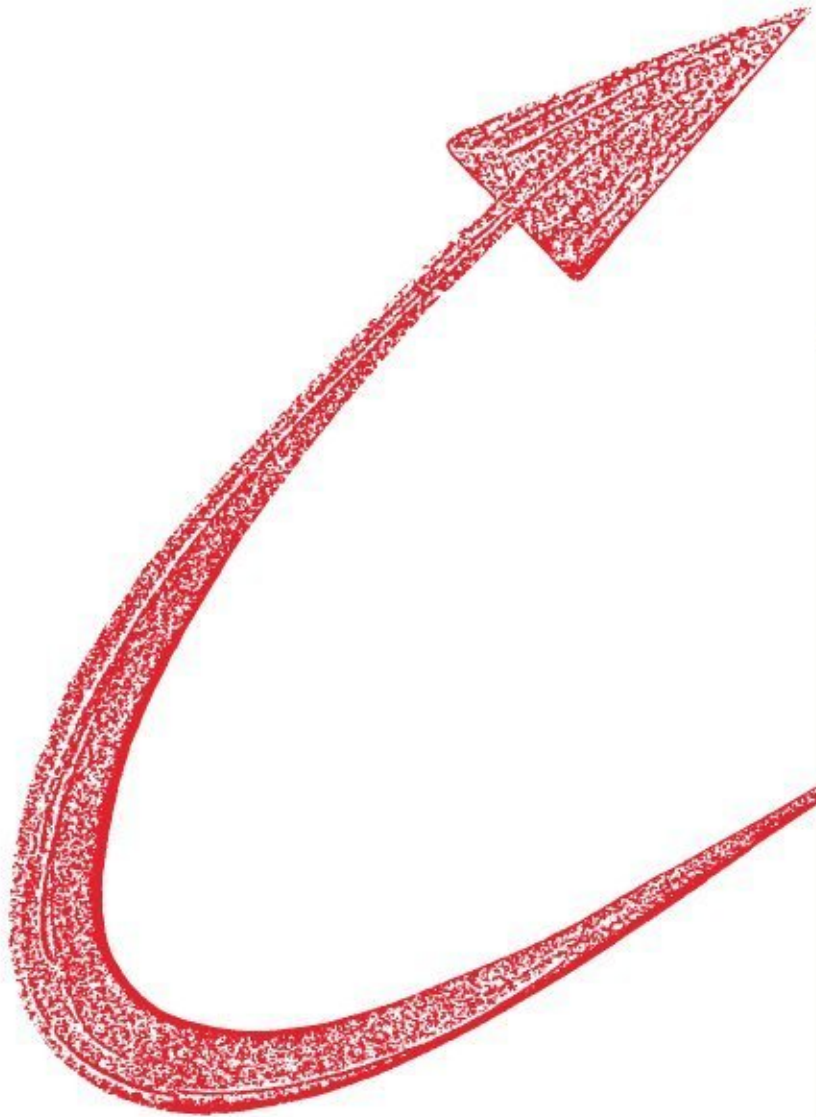

Manual Presses

Pneumatic Presses

Hydro - Pneumatic Presses



LIST OF CONTENTS

Toggle presses

Manual toggle presses
with round ram

5 kN	4
7,5 kN	5
15 kN, 25 kN, 30 kN	6 + 7

Manual toggle presses
with square ram

5 kN, 7,5 kN	8
15 kN, 25 kN	9

Pneumatic toggle presses

5 kN, 10 kN	10
24 kN, 32 kN, 60 kN	11

Manually assisted pneumatic
toggle presses

12 + 13

Direct acting presses

Rack-and-pinion presses
with round ram

1,5 kN, 2,5 kN	14
----------------	----

Rack-and-pinion presses
with square ram

1,5 kN, 2,5 kN	15
----------------	----

Pneumatic presses

DA series 1.5 kN, 2.5 kN	16
DA series 4.5 - 13 kN - throat 80 mm	17
DA series 4.5 - 17 kN - throat 100 mm	18
DA series 4.5 - 17 kN - throat 130 mm	18
XL DA series 4.5 - 17 kN - throat up to 300 mm	19
DA series 21 kN, 28 kN, 34 kN	20
XL DA series 21 kN, 28 kN, 34 kN - throat up to 300 mm	20

Hydro-pneumatic presses

HP series 30 kN, 50 kN, 100 kN	21
--------------------------------	----

XL-HP series 30 kN, 50 kN	22
---------------------------	----

Press control systems	23
------------------------------	----

Total Press Control Plus

Force/displacement monitoring	24 + 25
-------------------------------	---------

Press heads	26
-------------	----

Tools	26
-------	----

Special models	26
----------------	----

Pneumatic slide table	27
------------------------------	----

presses can perform a variety of tasks quickly, precisely and easily. Examples are:

Assembling

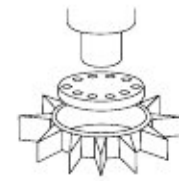

Pressing-in

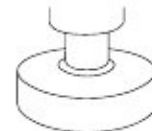

Bending

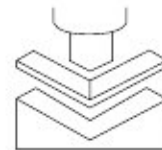

Riveting



Cutting

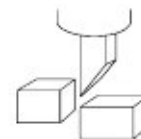

Punching

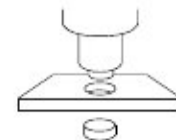

Crimping

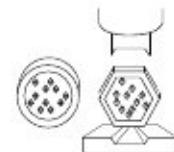

Stamping

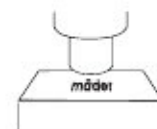

We reserve the right to make technical modifications.

EXTRAS FOR MANUAL PRESSES

Return travel lock (HS)

With the return travel lock for manual toggle presses and rack-and-pinion presses, partial strokes - and hence incomplete work operations - are ruled out. Forming, joining or connecting operations are carried out safely and completely at all times: an effective contribution to quality assurance.

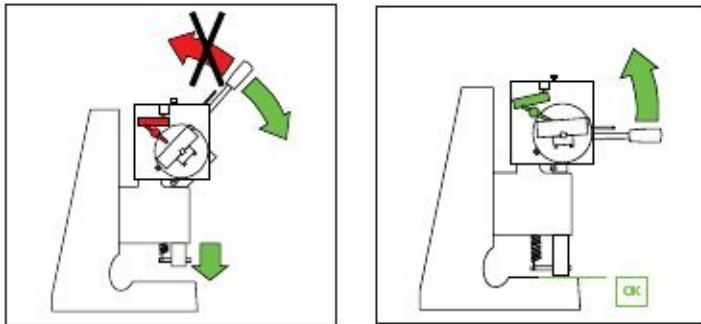

On the down stroke, the return stroke of the press is blocked. The locking device is not released and the lever is not reset until after completion of the stroke. A release mechanism permits removal of jammed components.

Table bore (TB)

Tool undersides can be seated in the table bore and secured using a transverse screw. The table bore permits rapid tool-changing and greatly reduces setting-up times. This option is possible on **all manual presses or with other presses** on request.



Standard



Table bore (TB)

Stroke counter (Z)

with the five-digit stroke counter, the number of items produced can be checked rapidly.

This option is available for **all manual presses**.



Choice of colours for all presses



standard colour
(RAL 5021)

optional colour at no
extra cost (RAL 7035)

choice of colours from the RAL
range at extra cost

Precision ram adjustment (DP)

Since toggle presses only produce their maximum force at the end of the working stroke, the height setting of the press head with the threaded spindle is often too inexact. Using the fine adjustment, the bottom dead centre (BDC) of the press can be precisely set directly on the ram. A scale on the setting ring permits a readable fine adjustment of 0.02 mm. The adjustment range is ± 1.5 mm. The precision ram adjustment is used where highest precision of the insertion depth is required. Ideal for prototype production and series production when delicate, minute setting within the tolerance range is required.

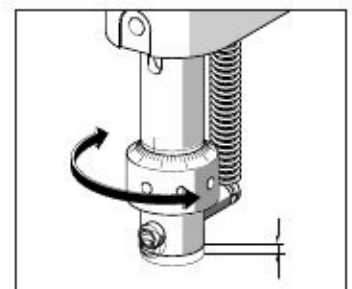

Micrometer stop

For high-precision assembly work **with rack-and-pinion presses** when it is important that the workpiece is positioned with great accuracy.



Micrometer stop (Micro)

TOGGLE PRESSES

Manual toggle presses with round ram EP series

Toggle presses only produce their rated force at the end of the stroke, the bottom dead centre (BDC). In doing so, the high working pressure of the press is achieved using the toggle mechanism with a relatively low effort (approximately 150 N) on the part of the user.

Toggle presses are therefore used where the full force of the press is only required over a short distance at the end of the working stroke, e.g. in assembling, punching, riveting, stamping, gluing etc.

All toggle presses are distinguished by the following quality features:

- factory-set bottom dead centre (BDC)
- simple adjustment of the height of the press head using a threaded spindle
- hardened and ground ram
- long, honed and therefore highly precise ram guide
- ground press table



EP 500 - 40

EP - the ERGOPRESS® series
the concept of a modern, ergonomic manual toggle press for manual workstations in industrial series production.

The ERGOPRESS® models represent a logical further development of the manual press-in technology.



ERGOPRESS® hand lever switched-over for left-handed operation

ERGOPRESS® hand lever

- 360° variably adjustable hand lever
- the basic version of the press can be rapidly adapted for left- or right-handed operation just by switching over the toggle lever
- the laterally offset lever ensures unobstructed view of the work area

This means higher output through optimum de-stressing: with ERGOPRESS®, cramped and incorrect posture during operation is a thing of the past. This reduces absenteeism, increases the motivation of personnel, makes work easier and lowers production costs.

Type		EP 500-40	
Capacity		kN	5.0
		kp	500
Working stroke		mm	40
Throat	A	mm	63
Daylight	B	mm	45 - 220
Daylight with DP	B	mm	30 - 205
Table size	C x D	mm	100 x 65
T-slot width similar to DIN 650		mm	10
Ram bore Ø x depth	E	mm	10" x 25
Ram Ø	F	mm	20
Space requirement	C x G	mm	110 x 160
Weight		kg	approx. 10

Extras (see Page 3)	Please indicate with order
Precision ram adjustment	DP
Return travel lock	HS
Stroke counter	Z
Table bore 12"	TB

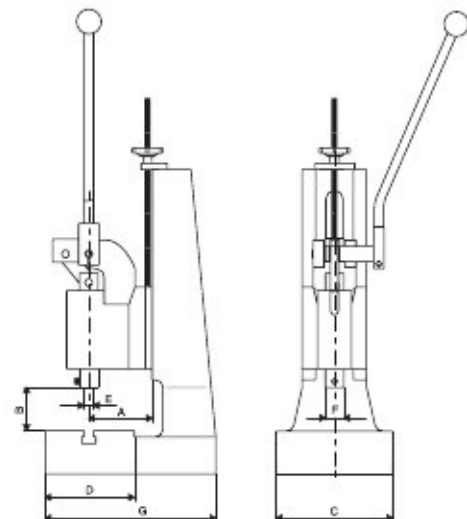

TOGGLE PRESSES

Manual toggle presses with round ram EP series / L-EP series with extra-high daylight

L-presses are used wherever tall or long parts are either machined or pressed in and therefore require a high daylight.

Possible applications:

- for applications and tools, which require a large installation area, for example:
 - when pressing-in long axes or
 - when bushing or machining tall parts



EP 750 - 40

Press with return travel lock (HS) and precision ram adjustment (DP)

L-EP 750 - 40

Press with return travel lock (HS), precision ram adjustment (DP) and stroke counter (Z)

Type		EP 750-40	L-EP 750-40
Capacity	kN	7.5	7.5
	kp	750	750
Working stroke	mm	40	40
	Throat	A	80
Daylight	B	mm 48 - 208	55 - 375
	Daylight with DP	B	mm 32 - 192
Table size	C x D	mm 155 x 115	155 x 115
T-slot width similar to DIN 650		mm 12	12
Ram bore Ø x depth	E	mm 10" x 25	10" x 25
Ram Ø	F	mm 24	24
Space requirement	C x G	mm 155 x 220	155 x 220
Weight		kg approx. 20	28

Extras (see Page 3)	Please indicate with order	
Precision ram adjustment	DP	DP
Return travel lock	HS	HS
Stroke counter	Z	Z
Table bore 12°	TB	TB

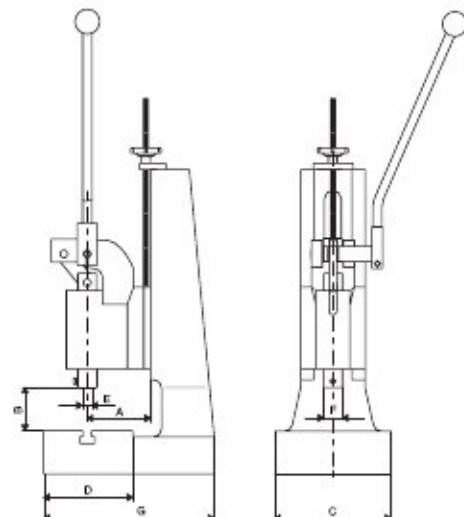

TOGGLE PRESSES

Manual toggle presses with round ram APK T series

The extra-powerful manual toggle presses of the APK T 3 and APK T 4 series are especially suitable for frequently changing applications in model construction and in the workshop. The high capacity of up to 30 kN permits flexible usage for a wide variety of applications.

The advantages:

- different stroke lengths available
- extra-rigid design of press base
- the working height can be easily adjusted via the standard height setting of the press head using a threaded spindle
- the nominal capacity of the press can be achieved with minimal effort
- silicone-free textured paint finish



APK T 3-40

Illustration with precision ram adjustment (DP) and stroke counter (Z)

APK T 3-S-60

Type			APK T 3-40	APK T 3-60	APK T 3-S-40	APK T 3-S-60	APK T 4-30
Capacity		kN	15.0	15.0	25.0	25.0	30.0
		kp	1500	1500	2500	2500	3000
Working stroke		mm	40	60	40	60	30
Throat	A	mm	100	100	100	100	100
Daylight	B	mm	43 - 164	43 - 170	60 - 290	65 - 295	55 - 285
Daylight with DP	B	mm	29 - 150	22 - 149	46 - 274	44 - 274	34 - 264
Table size	C x D	mm	175 x 140	175 x 140	185 x 145	185 x 145	185 x 145
T-slot width similar to DIN 650		mm	12	12	12	12	12
Ram bore Ø x depth	E	mm	10" x 30	10" x 30	10" x 30	10" x 30	10" x 30
Ram Ø	F	mm	30	30	30	30	30
Space requirement	C x G	mm	175 x 300	175 x 300	185 x 300	185 x 300	185 x 300
Weight		kg	approx. 39	approx. 43	approx. 41	approx. 46	approx. 46

Extras (see Page 3)	Please indicate with order				
Precision ram adjustment	DP	DP	DP	DP	DP
Return travel lock	HS	HS	HS	HS	HS
Stroke counter	Z	Z	Z	Z	Z
Table bore 12°	TB	TB	TB	TB	TB

TOGGLE PRESSES

Manual toggle presses with round ram XL-APK T series presses with 250 mm throat

Wherever oversized components have to be processed, a larger throat is needed, for example to process PCB, sheet materials and similar pieces. For this purpose, XL presses with 250 mm throat are used.

The base is a durable welded construction on which the different standard press heads are mounted.



XL-APK T 3-40

Type		XLAPK T 3-40	XLAPK T 3-60
Capacity	kN	15.0	15.0
	kp	1500	1500
Working stroke	mm	40	60
Throat	A	250	250
Daylight	B	90 - 176	90 - 183
Daylight with DP	B	86 - 162	69 - 162
Table size	C x D	200 x 200	200 x 200
T-slot width similar to DIN 650	mm	12	12
Ram bore Ø x depth	E	10" x 30	10" x 30
Ram Ø	F	30	30
Space requirement	C x G	200 x 450	200 x 450
Weight	kg	approx. 54	approx. 58

Extras (see Page 3)	Please indicate with order	
Precision ram adjustment	DP	DP
Return travel lock	HS	HS
Stroke counter	Z	Z
Table bore 12"	TB	TB

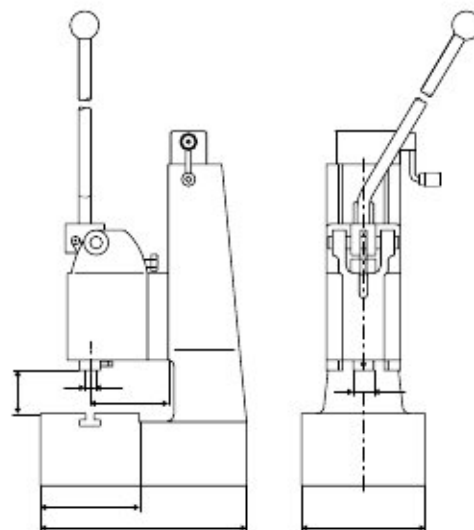

TOGGLE PRESSES

Manual toggle presses with square ram VK series / L-VK series

The square ram has significant advantages over the round ram:

- absolute torsion resistance
- hardened, precisely ground ram
- play-free movement of the press ram
- adjustable jib strips of the square ram
- large support surface for the tool
- guides on the tool are therefore usually unnecessary
- virtually maintenance-free operation

Additional standard equipment:

- height adjustment of the press head using a threaded spindle
- side-located measuring strip for repeatably accurate setting of press head

These models can also be fitted with the usual extras:

- Precision ram adjustment for precise setting of the insertion depth (DP)
- Return travel lock for quality assurance during production (HS)
- Stroke counter (Z)
- Central table bore (TB)

manual toggle presses with square rams are ideal tools for the production of high-precision small components with narrow tolerances in small and medium batches, where automation would be uneconomical.



VK 750-40

L-VK 750-40

Type		VK 500-40	VK 750-40	L-VK 750-40
Capacity	kN	5.0	7.5	7.5
	kp	500	750	750
Working stroke	mm	40	40	40
Throat	A	63	80	80
Daylight	B	45 - 220	48 - 208	55 - 375
Daylight with DP	B	30 - 205	32 - 192	39 - 359
Table size	C x D	100 x 65	155 x 115	155 x 115
T-slot width similar to DIN 650	mm	10	12	12
Ram bore Ø x depth	E	10" x 25	10" x 25	10" x 25
Ram cross-section	H	21 x 21	25 x 25	25 x 25
Space requirement	C x G	110 x 160	155 x 220	155 x 220
Weight	kg	approx. 10	approx. 20	approx. 28

Extras (see Page 3)	Please indicate with order		
Precision ram adjustment	DP	DP	DP
Return travel lock	HS	HS	HS
Stroke counter	Z	Z	Z
Table bore 12"	TB	TB	TB

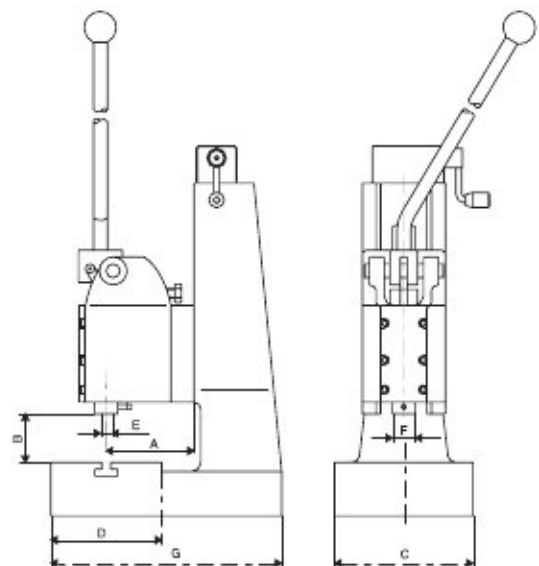

TOGGLE PRESSES

Manual toggle presses with square ram
VK series / XL-VK series / PHK series



VK 1500-40



PHK 600

The proven PHK 600 rounds off the range of toggle presses with square rams.

Type		VK 1500-40	VK 1500-60	VK 2500-40	VK 2500-60	XLVK 1500-40	XLVK 1500-60	PHK 600-08	
Capacity	kN	15.0	15.0	25.0	25.0	15.0	15.0	6.0	
	kp	1500	1500	2500	2500	1500	1500	600	
Working stroke	mm	40	60	40	60	40	60	25	
Throat	A	mm	100	100	100	250	250	85	
Daylight	B	mm	43 - 164	43 - 170	60 - 290	65 - 295	90 - 176	91 - 183	60 - 140
Daylight with DP	B	mm	32 - 153	26 - 153	46 - 274	44 - 274	79 - 165	74 - 166	-
Table size	C x D	mm	175 x 140	175 x 140	185 x 145	185 x 145	200 x 200	200 x 200	160 x 100
T-slot width DIN 650		mm	12	12	12	12	12	12	ø 10,5
Ram bore Ø x depth	E	mm	10" x 30	10" x 30	10" x 30	10" x 30	10" x 30	10" x 30	8x6 x 25*
Ram cross-section	H	mm	31 x 31	31 x 31	31 x 31	31 x 31	31 x 31	31 x 31	25 x 35
Fixing holes	6 x	mm	-	-	-	-	-	-	-
Space requirement	C x G	mm	175 x 300	175 x 300	185 x 300	185 x 300	200 x 450	200 x 450	160 x 220
Weight	kg	approx. 39	approx. 43	approx. 41	approx. 46	approx. 55	approx. 59	approx. 18	

Extras (see Page 3)	Please indicate with order						
Precision ram adjustment	DP	DP	DP	DP	DP	DP	-
Return travel lock	HS	HS	HS	HS	HS	HS	HS
Stroke counter	Z	Z	Z	Z	Z	Z	Z
Table bore 12"	TB	TB	TB	TB	TB	TB	Standard

* Other ram bores on request

TOGGLE PRESSES

Pneumatic toggle presses APK series

The optimum transmission ratios of the toggle press produce high forces at the end of the stroke, ensuring low air consumption. Thanks to the resultant low energy consumption, pneumatic toggle presses are an economical means of production not only at the time of purchase, but also in the long term.

All pneumatic toggle presses can be supplied with standard controls (see page 23) or with controls made to customers' specification.

Further quality features:

- factory-set bottom dead centre (BDC)
- simple height adjustment of the press head using a bevel gear
- side-mounted measuring strip for rapid repetition of settings when changing tools
- virtually maintenance-free double-action cylinder
- low noise: under 75 dBA

The detail shows:

- Measuring strip
- Crank handle of the bevel gear for infinitely variable height adjustment of the press head
- Pneumatic system, valve and service unit with air filter, oiler and pressure reducer (only in versions supplied with controls)



APK 2L

Type		APK 2 L	APK 3 L
Capacity at 6 bar	kN	5	10
	kp	500	1000
Working stroke	mm	35	40
Throat	A	mm	80
	B	mm	100
Daylight	B	mm	62 - 192
Daylight with DP	B	mm	110 - 280
Table size	C x D	mm	46 - 176
		mm	-
T-slot width similar to DIN 650		mm	155 x 115
		mm	185 x 145
Ram bore Ø x depth	E	mm	12
	F	mm	12
Ram Ø	F	mm	10" x 25
		mm	12" x 30
Port size			R 1/4"
			R 1/4"
Air consumption/cm cyl. stroke	L		0.26
			0.41
Space requirement	C x G	mm	155 x 220
		mm	185 x 300
Weight	kg	approx 22	approx 38

Extras (see Page 3)	Please indicate with order
Precision ram adjustment	DP

Valve and service unit only in versions supplied with controls

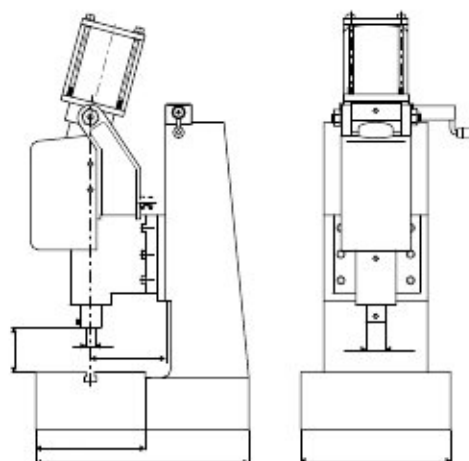

TOGGLE PRESSES

Pneumatic toggle presses
APK series



APK 4 L

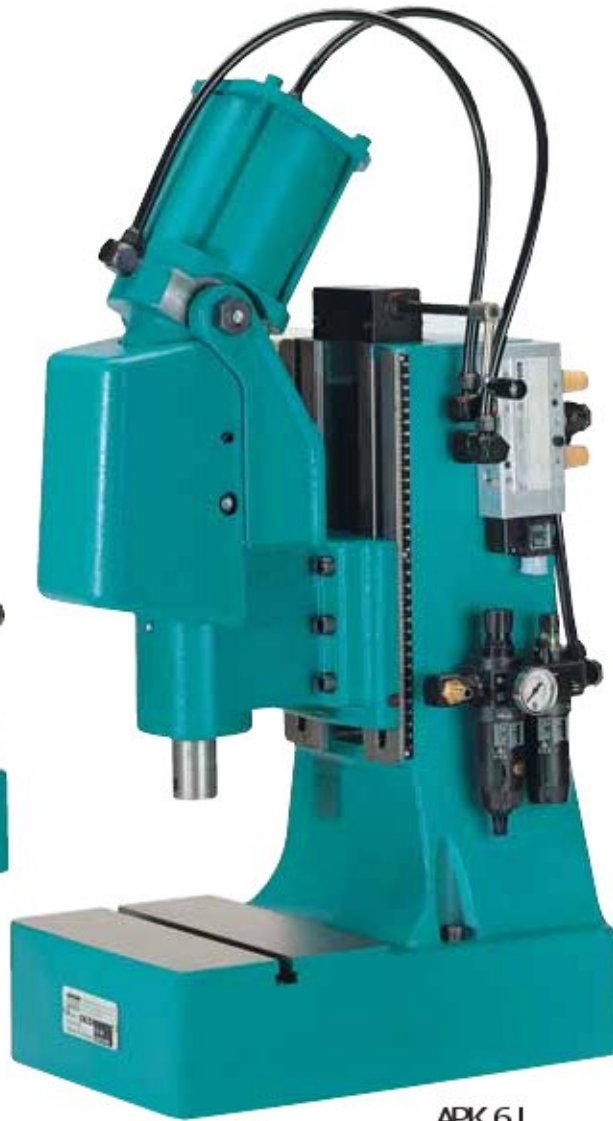

APK 6 L

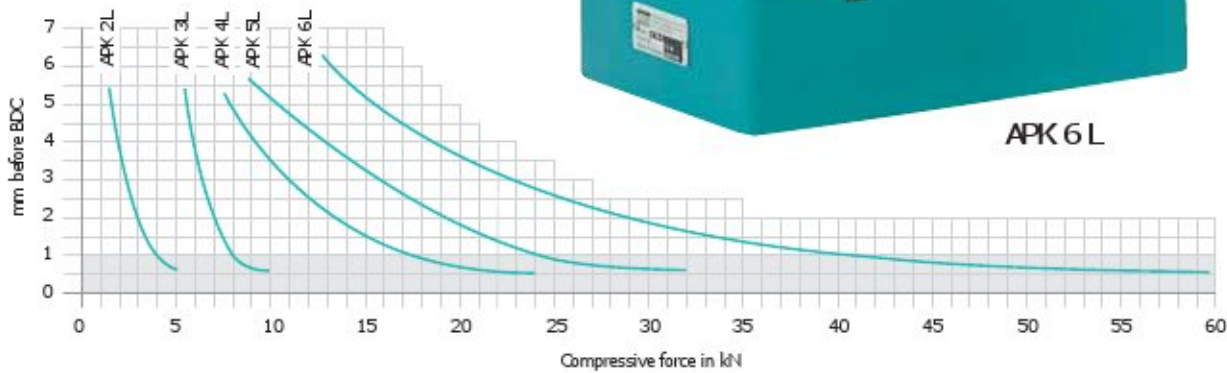

Type		APK 4 L	APK 5 L	APK 6 L	XL APK 4 L	XL APK 5 L	XL APK 6 L
Capacity at 6 bar	kN	24	32	60	24	32	60
	kp	2400	3200	6000	2400	3200	6000
Working stroke	mm	40	40	40	40	40	40
Throat	A	mm	130	130	300	300	300
	B	mm	175 - 330	175 - 330	130 - 280	130 - 280	130 - 230
Table size	C x D	mm	200 x 190	200 x 190	200 x 220	200 x 220	310 x 220
T-slot width similar to DIN 650	mm	14	14	14	14	14	14
Ram bore Ø x depth	E	mm	12" x 30	12" x 30	12" x 30	12" x 30	20" x 34
Ram Ø	F	mm	30	30	30	30	40
Port size			R 3/8"	R 3/8"	R 3/8"	R 3/8"	R 3/8"
Air consumption/cm cyl. stroke	l	1.05	1.05	1.65	1.05	1.05	1.65
Space requirement	C x G	mm	200 x 385	200 x 385	200 x 550	200 x 550	310 x 580
Weight	kg	approx 72	approx 80	approx 140	approx 196	approx 204	approx 250

Valve and service unit only in versions supplied with controls

TOGGLE PRESSES

Manually assisted pneumatic toggle presses NP series

Manually assisted toggle presses are used when, due to the special nature of the workpiece, it is not initially possible to use both hands for two-handed operations and yet a large compression force is required at the end of the working stroke.

With NP manually assisted pneumatic toggle presses, safe working is possible in these circumstances: the ram is brought to the pressure position of the stroke using the hand lever and the workpiece is then held by the force of this lever. A sensor registers this position. At the same time, the workpiece can be released and a button pushed using the other hand, which then initiates the power stroke.

The power stroke can only be initiated when both hands are occupied. So, if the hand lever is released, the ram is raised by a safety mechanism and the enable signal for the power stroke in the control system is removed.

The length of the power stroke in NP manually assisted pneumatic toggle presses and hence the BDC position can be set with high accuracy using the standard precision adjustment facility.

Thanks to the specially designed transmission mechanism, a uniform pressure is available over the whole length of the selected stroke.



Power stroke precision adjustment

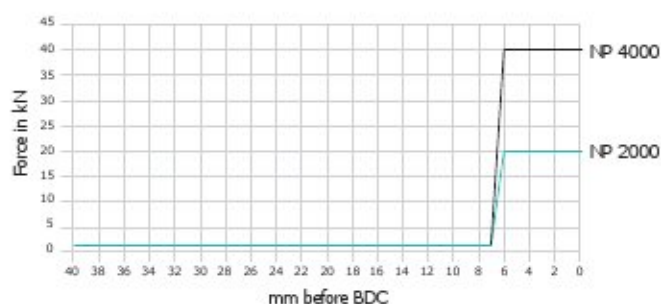

Type		NP 2000	NP 4000
Capacity	kN	20	40
	kp	2000	4000
Working stroke	mm	40	40
Power stroke	mm	0 - 6	0 - 6
Throat	A	mm	130
	B	mm	58 - 325
Daylight	B	mm	58 - 325
Table size	C x D	mm	200 x 190
T-slot width similar to DIN 650		mm	14
Ram bore Ø x depth	E	mm	20" x 25
Ram cross-section	F	mm	40 x 40
Port size			R 3/8"
Air consumption/mm cyl. stroke	I		0.5
Space requirement	C x G	mm	200 x 385
		kg	approx. 95
Weight			approx. 96

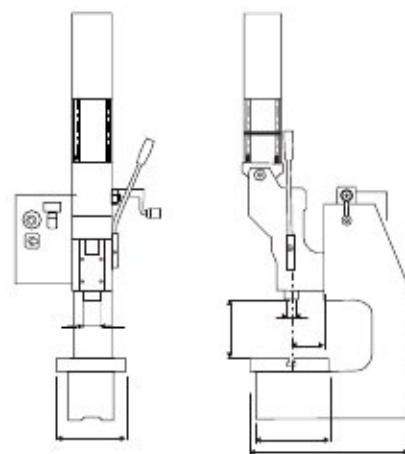

TOGGLE PRESSES

Manually assisted pneumatic toggle presses
XL-NP series



XL-NP 4000

Type		XL-NP 2000	XL-NP 4000
Capacity	kN	20	40
	kp	2000	4000
Working stroke	mm	40	40
Power stroke	mm	0 - 6	0 - 6
Throat	A	mm	300
	B	mm	125 - 265
Daylight	B	mm	125 - 265
Table size	C x D	mm	200 x 220
T-slot width similar to DIN 650		mm	14
Ram bore Ø x depth	E	mm	20" x 25
Ram cross-section	F	mm	40 x 40
Port size			R 3/8"
Air consumption/mm cyl. stroke	I		0.5
Space requirement	C x G	mm	200 x 550
		kg	approx. 135
Weight			approx. 136

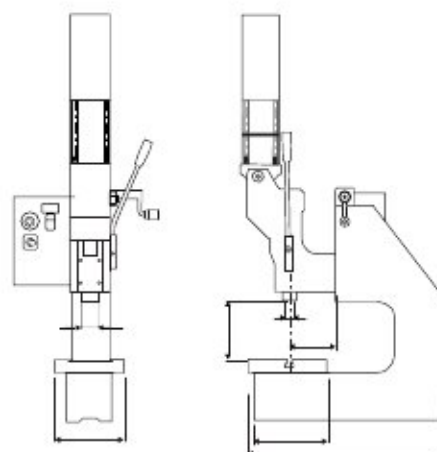

DIRECT ACTING PRESSES

Rack-and-pinion presses with round ram APZ series

rack-and-pinion presses transmit their pressing force constantly over the entire length of the stroke. Direct power transmission via the hand lever permits extreme precision in the pressing operation.

The improved transmission ratio enables a higher compression force to be achieved for the same force applied.

The following quality features are characteristic of all rack-and-pinion presses:

- anti-twist ram
- infinitely adjustable stroke length:
Standard: via setting screw
MICRO: via micrometer screw
- Height adjustment of the press head using a threaded spindle
- 360° infinitely adjustable hand lever
- adjustable return stroke power

Rack-and-pinion presses are therefore ideal for:

- pressing-in longer components and for
- jointing operations over long strokes



APZ T 1

APZ T 2

Type			APZ T 1	APZ T 2	L-APZ T 2
Capacity		kN	1.5	2.5	2.5
		kp	150	250	250
Working stroke*		mm	40/90*	50/100*	50/100*
Throat	A	mm	63	80	80
Daylight	B	mm	50 - 240	46 - 242	55 - 390
Table size	C x D	mm	100 x 65	155 x 115	155 x 115
T-slot width similar to DIN 650		mm	10	12	12
Ram bore Ø x depth	E	mm	10" x 25	10" x 25	10" x 25
Ram Ø		mm	25	25	25
Space requirement	C x G	mm	110 x 160	155 x 220	155 x 220
Weight		kg	approx: 8.5	approx: 21	approx: 29

Extras (see Page 3)	Please indicate with order		
Return travel lock	HS	HS	HS
Micrometer	MICRO	MICRO	MICRO
Stroke counter	Z	Z	Z
Table bore 12"	TB	TB	TB

*Please indicate stroke length with order

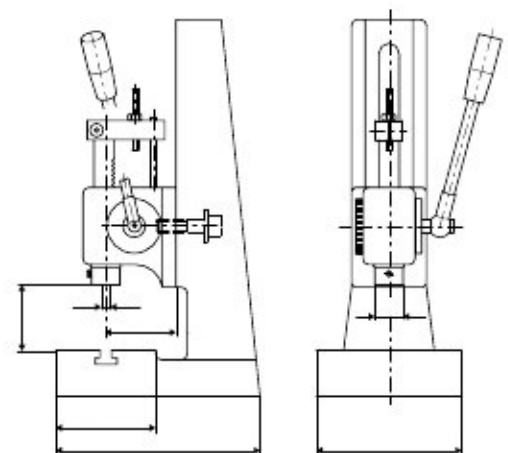

DIRECT ACTING PRESSES

Rack-and-pinion presses with square ram VZ series

The square ram has significant advantages over the round ram:

- absolute torsion resistance
- play-free movement of the press ram
- adjustable jib strips of the square ram
- large support surface for the tool
- guides on the tool are therefore usually unnecessary
- virtually maintenance-free operation

Additional standard equipment:

- height adjustment of the press head using a threaded spindle
- side-located measuring strip for repeatably accurate setting of press head
- these models can also be fitted with the usual extras

rack-and pinion presses with square rams are ideal tools for the production of high-precision small components with narrow tolerances in small and medium batches, where automation would be uneconomical.



VZ 150-40

L-VZ 250-50

Press with micrometer screw

Type		VZ 150	VZ 250	L-VZ 250
Capacity	kN	1.5	2.5	2.5
	kp	150	250	250
Working stroke	mm	40/90*	50/100*	50/100*
Throat	A	mm	63	80
Daylight	B	mm	35 - 235	30 - 220
Table size	C x D	mm	100 x 65	155 x 115
T-slot width similar to DIN 650		mm	10	12
Ram bore Ø x depth	E	mm	10" x 25	10" x 25
Ram cross section	F	mm	20 x 20	20 x 20
Space requirement	C x G	mm	110 x 160	155 x 220
Weight	kg	approx. 8.5	approx. 21	approx. 29

Extras (see Page 3)	Please indicate with order		
Return travel lock	HS	HS	HS
Micrometer	MICRO	MICRO	MICRO
Stroke counter	Z	Z	Z
Table bore 12"	TB	TB	TB

*Please indicate stroke length with order

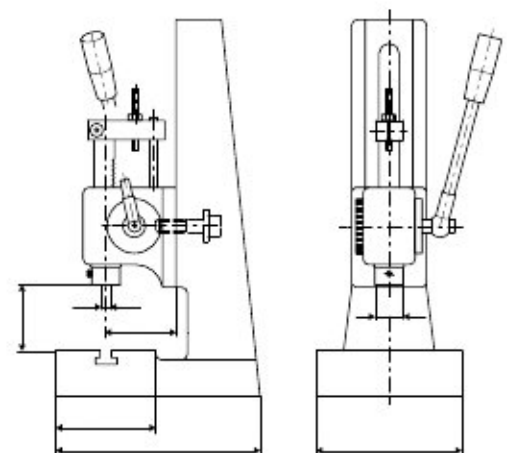

DIRECT ACTING PRESSES

Direct acting pneumatic presses DA series

Direct acting pneumatic presses develop their power uniformly over the entire length of the stroke.

Where higher forces are involved, the energy-saving tandem cylinder type is used. This type optimises compressed air consumption, since the return stroke is performed by only one cylinder chamber. Because the air input takes place inside the pneumatic cylinder, the press can only be operated with 2 air connections.

All direct acting pneumatic presses are available as an automation module or can be supplied with controls (see Page 23) for individual workstations.

Further quality features:

- hardened anti-twist ram
- long, honed ram guide for highest precision
- three standard lengths of stroke
- simple height adjustment of the press head using a threaded spindle
- side-mounted measuring strip for rapid repetition of settings when changing tools
- virtually maintenance-free double-action cylinders
- low noise: under 75 dBA



DA 150-63-80



DA 250-80-80
L-DA 250-80-80

Type		DA 150-80-63	DA 250-80-80	L-DA 250-80-80	
Capacity at 6 bar		kN	1.5	2.5	2.5
		kp	150	250	250
Working stroke		mm	80	80	80
Throat	A	mm	63	80	80
Daylight	B	mm	40 - 215	70 - 280	65 - 390
Table size	C x D	mm	100 x 65	157 x 115	155 x 115
T-slot width similar to DIN 650		mm	10	12	12
Ram bore	E	mm	16" x 25	20" x 25	20" x 25
Ram Ø	F	mm	30	40	40
Port size			R 1/4"	R 1/4"	R 1/4"
Air consumption/ 10mm stroke		I	0.2	0.3	0.3
Space requirement	C x G	mm	110 x 160	157 x 237	155 x 220
Weight		kg	approx. 11,5	approx. 18,5	approx. 31

Extras	Please indicate with order		
Table bore 12"	TB	TB	TB

Valve and service unit only in versions supplied with controls

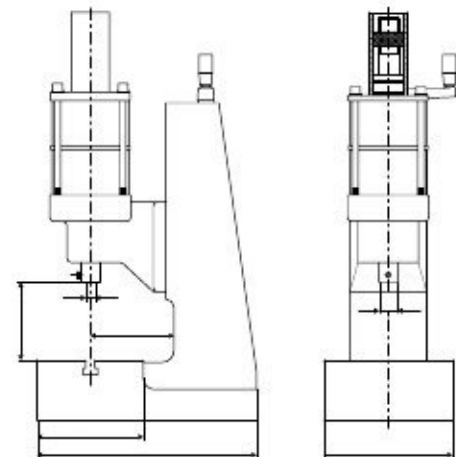

DIRECT ACTING PRESSES

Direct acting pneumatic presses DA series

DA presses are the logical implementation of modern press technology for direct acting pneumatic presses. Thanks to their modular construction, the exact size required for the particular application can be chosen. In this way the price/performance ratio is maximised.

Stroke lengths of 40 mm, 60 mm, and 80 mm are available as standard. Special lengths can be supplied on request.

The processing of sheet material, PCBs or other oversized components requires the press to have a larger throat. XL-DA presses with a throat of 250 mm or 300 mm enable even these parts to be processed.

For tall components, which require more space in the height axis, L-DA presses with up to 350 mm daylight are used.

Presses with stands in welded design can be manufactured to customers' requirements for dimensions which are outside the standard range.

DA presses are virtually maintenance-free, as all moving parts are mounted in bearings. The cylinders are pre-greased. Oil-free operation is therefore possible.



L-DA 1300-40-80

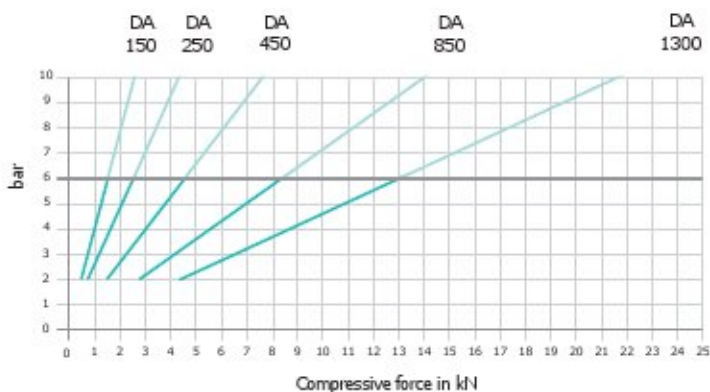

Type		DA 450- [*] -80	DA 850- [*] -80	LDA 450- [*] -80	LDA 850- [*] -80	LDA 1300- [*] -80	
Capacity at 6 bar	kN	4.5	8.5	4.5	8.5	13.0	
	kp	450	850	450	850	1300	
Working stroke [*]	mm	40/60/80	40/60/80	40/60/80	40/60/80	40/60/80	
Throat	A	mm	80	80	80	80	
Daylight	B	mm	58 - 243	58 - 243	65 - 350	65 - 350	65 - 350
Table size	C x D	mm	155 x 115	155 x 115	155 x 115	155 x 115	
T-slot width similar to DIN 650		mm	12	12	12	12	
Ram bore	E	mm	20" x 25	20" x 25	20" x 25	20" x 25	
Ram Ø	F	mm	40	40	40	40	
Port size			R3/8"	R3/8"	R3/8"	R3/8"	
Air consumption/ 10mm stroke	I		1.0	1.5	1.0	1.5	2.0
Space requirement	C x G	mm	155 x 220	155 x 220	155 x 220	155 x 220	
Weight		kg	approx 28	approx 31	approx 34	approx 37	approx 40

Valve and service unit only in versions supplied with controls

^{*}Please indicate stroke length with order

DIRECT ACTING PRESSES

Direct acting pneumatic presses DA series

DA presses are fitted as standard with an innovative, precise and easy-to-use system, which enables the stroke to be set accurately and safeguards the ram against twisting.

Quality features:

- The press-in depth can be accurately set to 0.05 mm over the whole length of the stroke using just one screw and can be read off on the side-mounted scale and the vernier on the adjusting nut (Figure 1).
- The end position damping of the working stroke can be activated using a screw (Figure 2).
- The position of the ram can be read by reed contacts, which are pushed on to the standard scale (Figure 3).
- The sensors do not have to be readjusted when the stroke length is changed, as the stroke length control solenoids always move to the same end positions (Figure 5).
- The ram is prevented from twisting by means of a double column guide (Figure 4).



Figure 1



Figure 5



Figure 2



Figure 3



Figure 4



DA 1300-40-130

DA 850-40-100

Type		DA 450- [*] -100	DA 850- [*] -100	DA 1300- [*] -100	DA 1700- [*] -100	DA 450- [*] -130	DA 850- [*] -130	DA 1300- [*] -130	DA 1700- [*] -130
Capacity at 6 bar	kN	4.5	8.5	13.0	17.0	4.5	8.5	13.0	17.0
	kp	450	850	1300	1700	450	850	1300	1700
Working stroke*	mm	40/60/80	40/60/80	40/60/80	40/60/80	40/60/80	40/60/80	40/60/80	40/60/80
Throat	A	mm	100	100	100	130	130	130	130
	B	mm	57 - 285	57 - 285	57 - 285	57 - 285	75 - 325	75 - 340	75 - 340
Daylight	B	mm	57 - 285	57 - 285	57 - 285	75 - 325	75 - 340	75 - 340	75 - 340
Table size	C x D	mm	185 x 145	185 x 145	185 x 145	185 x 145	200 x 190	200 x 190	200 x 190
T-slot width similar to DIN 650		mm	12	12	12	12	14	14	14
Ram bore Ø x depth	E	mm	20" x 25	20" x 25	20" x 25	20" x 25	20" x 25	20" x 25	20" x 25
	F	mm	40	40	40	40	40	40	40
Port size			R 3/8"	R 3/8"	R 3/8"	R 3/8"	R 3/8"	R 3/8"	R 3/8"
Air consumption/ 10mm stroke	I		1.0	1.5	2.0	2.5	1.0	1.5	2.0
Space requirement	C x G	mm	185 x 300	185 x 300	185 x 300	185 x 300	200 x 385	200 x 385	200 x 385
Weight	kg	approx 62	approx 65	approx 68	approx 71	approx 83	approx 86	approx 89	approx 92

*Please indicate stroke length with order

Valve and service unit only in versions supplied with controls

DIRECT ACTING PRESSES

Direct acting pneumatic presses
XL-DA series

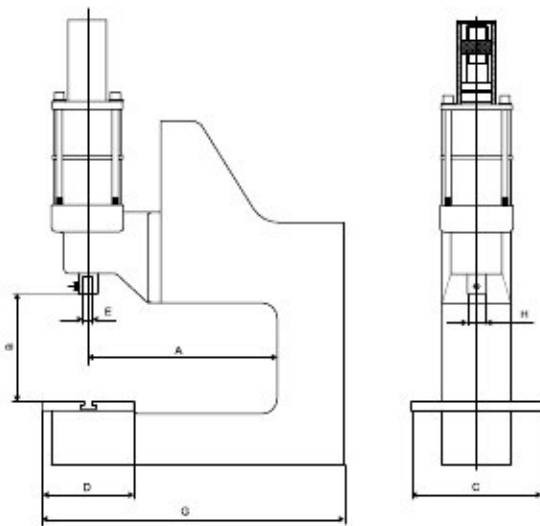

XL-DA 1300-40-300

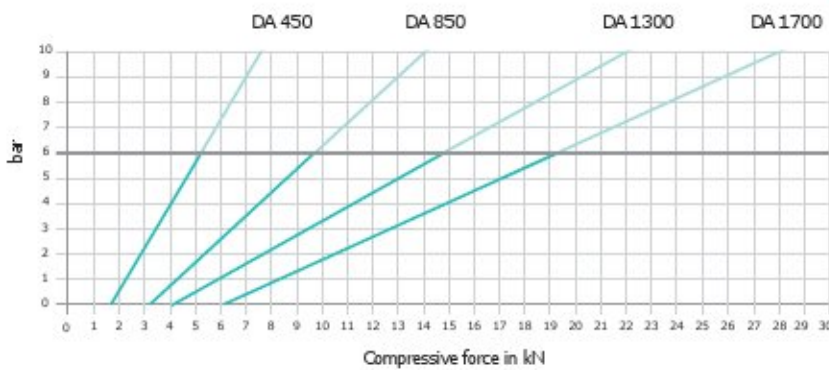

Type		XLDA 450-4-250	XLDA 850-4-250	XLDA 1300-4-250	XLDA 450-4-300	XLDA 850-4-300	XLDA 1300-4-300	XLDA 1700-4-300	
Capacity at 6 bar	kN	4.5	8.5	13.0	4.5	8.5	13.0	17.0	
	kp	450	850	1300	450	850	1300	1700	
Working stroke*	mm	40/60/80	40/60/80	40/60/80	40/60/80	40/60/80	40/60/80	40/60/80	
Throat	A	mm	250	250	300	300	300	300	
Daylight	B	mm	140 - 253	140 - 253	140 - 275	140 - 275	140 - 275	140 - 275	
Table size	C x D	mm	200 x 200	200 x 200	200 x 220	200 x 220	200 x 220	200 x 220	
T-slot width similar to DIN 650		mm	12	12	14	14	14	14	
Ram bore Ø x depth	E	mm	20" x 25	20" x 25	20" x 25	20" x 25	20" x 25	20" x 25	
Ram Ø	F	mm	40	40	40	40	40	40	
Port size			R 3/8"	R 3/8"	R 3/8"	R 3/8"	R 3/8"	R 3/8"	
Air consumption/ 10mm stroke	I		1.0	1.5	2.0	1.0	1.5	2.5	
Space requirement	C x G	mm	200 x 450	200 x 450	200 x 450	200 x 550	200 x 550	200 x 550	
Weight	kg		approx 57	approx 60	approx 63	approx 181	approx 184	approx 187	approx 190

*Please indicate stroke length with order

Valve and service unit only in versions supplied with controls

DIRECT ACTING PRESSES

Direct acting pneumatic presses DA series

The stroke of the DA series presses can be set with infinite variation using the scale screw with a reading accuracy of 0.05 mm.

The ram position can be read using the optional sensor kit. DA presses can therefore be used as an automation module as part of a complex application.

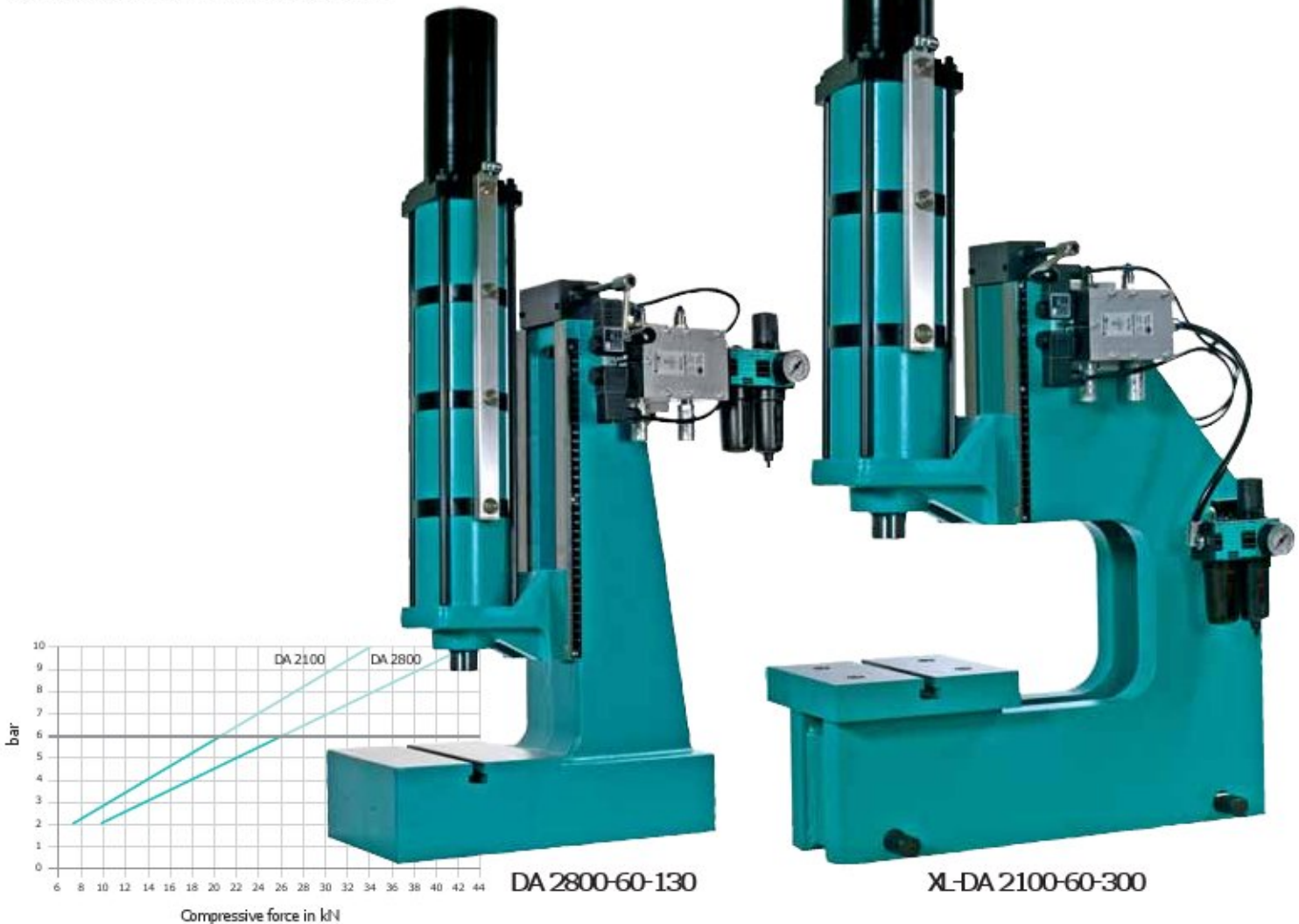

Type		DA 2100- ^k -130	DA 2800- ^k -130	DA 3400- ^k -130	XL-DA 2100- ^k -300	XL-DA 2800- ^k -300	XL-DA 3400- ^k -300	
Capacity at 6 bar		kN	21.0	28.0	34.0	21.0	28.0	34.0
		kp	2100	2800	3400	2100	2800	3400
Working stroke		mm	40/60/80	40/60/80	40/60/80	40/60/80	40/60/80	40/60/80
Throat presshead/guide		mm	130	130	130	300	300	300
Total Throat	A	mm				130	130	130
Daylight Presshead	B	mm	75 - 350	75 - 340	75 - 340	130 - 275	130 - 275	130 - 275
Daylight C-Frame		mm				158	158	158
Table size	C x D	mm	200 x 190	200 x 190	200 x 190	200 x 220	200 x 220	200 x 220
T-Slot width similar to DIN 650		mm	14	14	14	14	14	14
Ram bore x depth	E	mm	20" x 25	20" x 25	20" x 25	20" x 25	20" x 25	20" x 25
Ram ø	F	mm	40	40	40	40	40	40
Port size			R 3/8"	R 3/8"	R 3/8"	R 3/8"	R 3/8"	R 3/8"
Air consumption/ 10 mm stroke		l	3.0	3.7	4.5	3.0	3.7	4.5
Space requirement	C x G	mm	200 x 385	200 x 385	200 x 385	200 x 550	200 x 550	200 x 550
Weight		kg	ca. 81	ca. 86	ca. 92	ca. 194	ca. 199	ca. 205

*Please indicate stroke length with order

Valve and service unit only in versions supplied with controls

HYDRO-PNEUMATIC PRESSES

HP series

hydro-pneumatic presses are operated only by compressed air, activating the hydraulic power stroke automatically. They combine the advantages of pneumatic and hydraulic presses.

During the pneumatically operated rapid stroke, the workpiece is approached rapidly at low power. The hydraulic power stroke commences automatically as soon as resistance is met. This is why the input energy is used most economically with these models in particular. The operation of hydro-pneumatic presses is described on the following pages.

Since hydro-pneumatic presses do not require a hydraulic unit, they can be used even in the most confined spaces.

All hydro-pneumatic presses can be supplied with standard controls (see Page 23) or with controls made to customers' specification.

Further quality features:

- hardened anti-twist ram
- long, honed ram guide for highest precision
- two lengths of power stroke available
- simple height adjustment of the press head using a bevel gear
- side-mounted measuring strip for rapid repetition of settings when changing tools
- simple triggering as with double-action pneumatic cylinder
- low noise: under 75 dBA



HP 5000 HV

HP 10000 HV

Type		HP 3000 HV	HP 5000 HV	HP 10000 HV
Capacity at 6 bar	kN	30	50	100
	kp	3000	5000	10000
Total stroke	mm	40	50	50
thereof power stroke*	mm	4/8	5/10	5/10
Capacity of rapid stroke at 6 bar	kN	1.5	2.5	4.5
Capacity of return stroke at 6 bar	kN	1.3	1.7	4.1
Throat	A mm	130	150	150
	B mm	123 - 322	119 - 320	117 - 312
Daylight	B mm	123 - 322	119 - 320	117 - 312
Table size	C x D mm	200 x 190	305 x 210	310 x 220
T-slot width similar to DIN 650	mm	14	14	14
Ram bore Ø x depth	E mm	16" x 30	20" x 34	20" x 34
Ram Ø	F mm	35	40	40
Port size		R 1/4"	R 1/4"	R 1/4"
Space requirement	C x G mm	200 x 385	305 x 440	310 x 500
Weight	kg	approx. 78	approx. 163	approx. 287

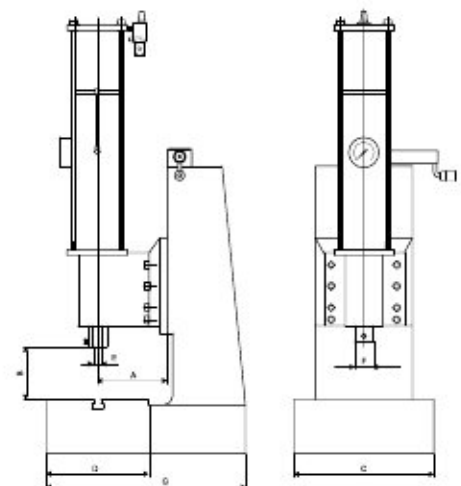

*Please indicate stroke length with order

Valve and service unit only in versions supplied with controls

HYDRO-PNEUMATIC PRESSES

XL-HP series



XL-HP 3000 HV

Typ		XL-HP 3000 HV	XL-HP 5000 HV
Capacity at 6 bar	kN	30	50
	kp	3000	5000
Total stroke	mm	40	50
thereof power stroke*	mm	4/8	5/10
Capacity of rapid stroke at 6 bar	kN	1.5	2.5
Capacity of return stroke at 6 bar	kN	1.3	1.7
Throat	A mm	300	300
Daylight	B mm	189 - 327	145 - 235
Table size	C x D mm	200 x 220	310 x 220
T-slot width similar to DIN 650	mm	14	14
Ram bore Ø x depth	E mm	16" x 30	20" x 34
Ram Ø	F mm	35	40
Port size		R 1/4"	R 1/4"
Space requirement	C x G mm	200 x 550	310 x 580
Weight	kg	approx. 184	approx. 241

* Please indicate stroke length with order

Valve and service unit only in versions supplied with controls

Function diagram

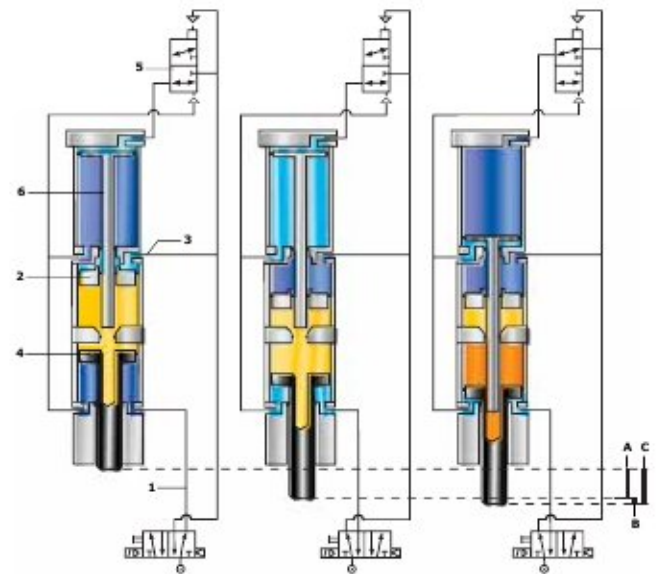

Oil without pressure
Oil under pressure

Air without pressure
Air under pressure

Description of operation:

Initial position:

Compressed air line (1) is charged with compressed air, the rest of the system is unpressurised.

Rapid stroke (A):

Pressure is applied to the rapid stroke piston (2) via the compressed air connection (3). The piston advances and, through the hydraulic oil, thrusts the power stroke piston (4) downwards at high-speed until contact is made with the workpiece.

Power stroke (B):

The changeover unit (5) switches over automatically; compressed air is applied to the plunger (6), which advances and closes the oil chamber so that power transmission takes place. In the power stroke, the ram (4) advances with reduced speed and high-power.

A = rapid stroke B = power stroke C = total stroke

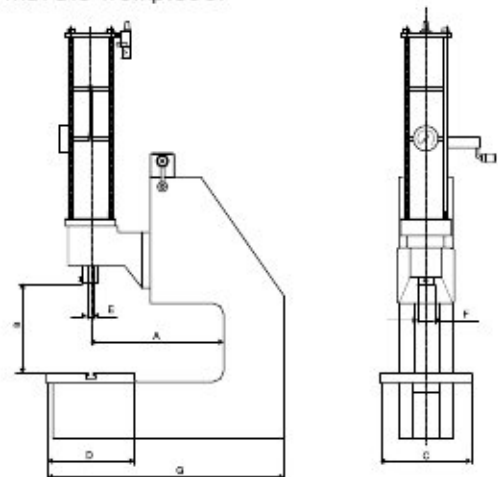

PRESS CONTROLS

For pneumatic presses

a variety
of control options for
pneumatic presses.

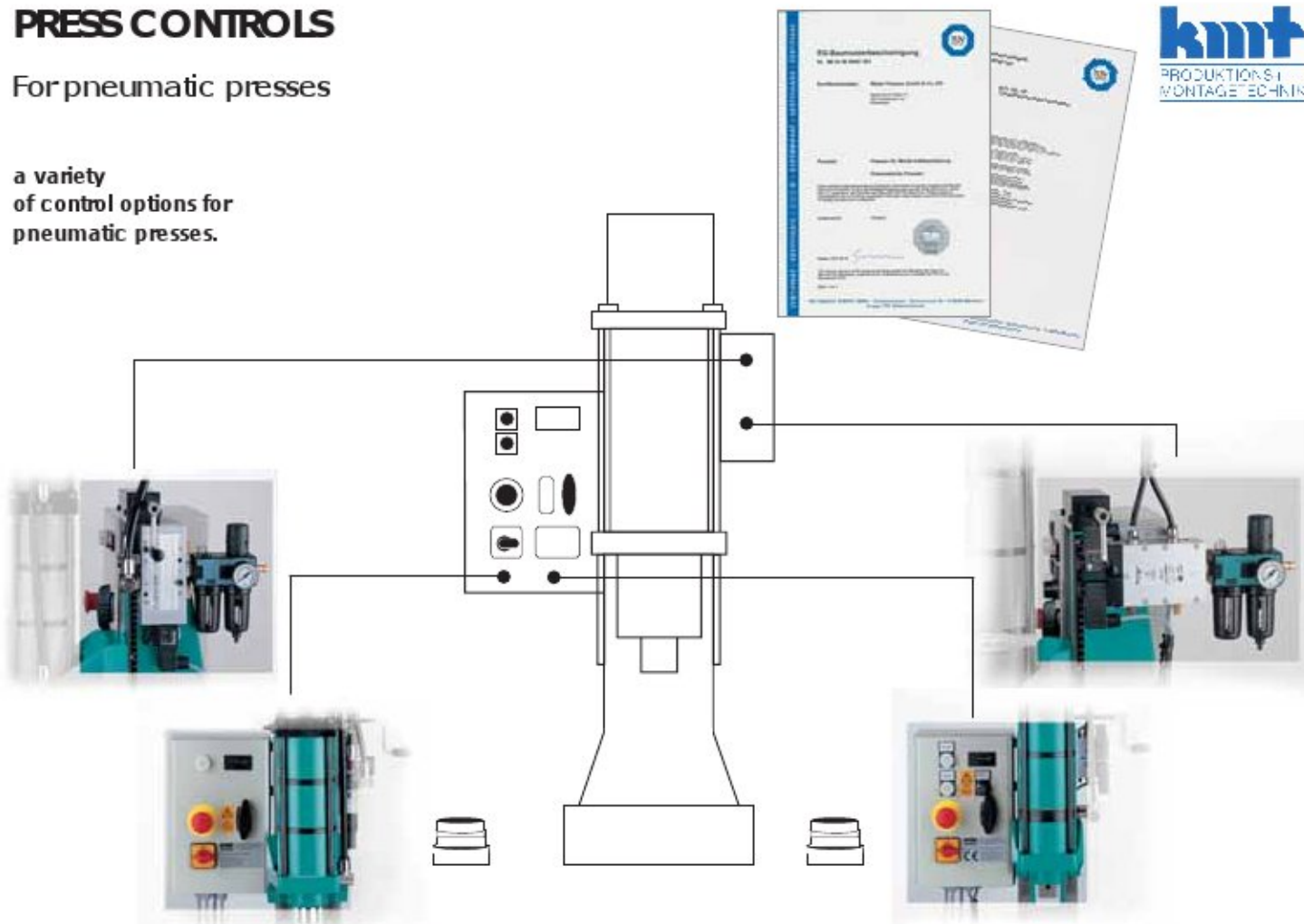

The following controllers can be used provided that safe tools are exclusively used or suitable safe-guarding of the danger area is provided:

E-ZH

Electro-pneumatic two-hand controller.

E-KOMBI

Electro-pneumatic two-hand controller with key-operated switch for changing over to the attached foot switch.

Included in the scope of supply of the E-ZH or E-KOMBI are:

- Electro-pneumatic valve
- Emergency stop
- Stroke counter
- Service unit consisting of pressure reducer with pressure gauge, filter and oiler.

This controller is approved for working in two-hand mode at workstations with manual loading and open tools. Here, safety is provided by the controller, which is designed to be both electrically and pneumatically redundant.

MPS-1

Electro-pneumatic two-hand safety controller with EC type test certificate.

It is possible to switch from two-hand mode to an external start signal for the press, e.g. a foot switch, by means of a key-operated switch. The foot switch or equivalent is not supplied with the MPS-1 controller.

MPS-1 PST

MPS-1 controller with an additional module for the control of presses and the PST 130 pneumatic slide table.

MPS-1 TPC

MPS-1 controller with an additional module TPC-PLUS for force/displacement monitoring. You will find details on the TPC-PLUS force/displacement monitoring system on the following pages.

The scope of supply of the MPS-1 controller includes:

- Type-tested press safety valve
- Emergency stop
- Stroke counter
- Service unit consisting of pressure reducer with pressure gauge, filter and oiler.

TOTAL PRESS CONTROL PLUS



Application example

Applications

Today, jointing and assembly tasks on presses must be performed reliably and – as far as possible – without subsequent checking. Specified parameters, which define the pressing-in process, must be maintained in production. Only in this way can the quality and reliability of the manufactured product be guaranteed. For this reason, TPC Plus is used wherever consistent jointing processes are required, the progression of which has to be monitored and, if necessary, documented using software.

TPC PLUS monitors the pressing-in process and the actual course of events is compared with the requirements and subsequently assessed. In this way, rejects are reliably identified and can be eliminated.

TPC PLUS is supplied with a PLC control system, onto which the hard-wired two-hand safety control MPS-1 is superimposed.

TPC PLUS is also available as a pure system module if a PLC environment is already available, e.g. in an automation system.

Operation

TPC PLUS can be easily programmed using the convenient membrane keypad or by using PC software. Logically constructed menu sequences enable you to find your way around quickly.

TPC PLUS stores 32 different measuring programmes, each with a maximum of 10 windows. TPC PLUS is therefore suitable for the wide range of models and the resulting shorter production cycles that are called for today.

TPC PLUS is equipped with a large, high-contrast display, which displays the entered or measured values either graphically or numerically. The graphical representation of characteristic curves is particularly helpful in the development phase. A reference curve can be stored and used as a basis for programming in later production.



Front panel, TPC unit

Evaluation

Different types of windows and the transition of the force/displacement curve can be freely selected with **TPC PLUS**. Insertion windows, pass-through windows, and block windows are available.

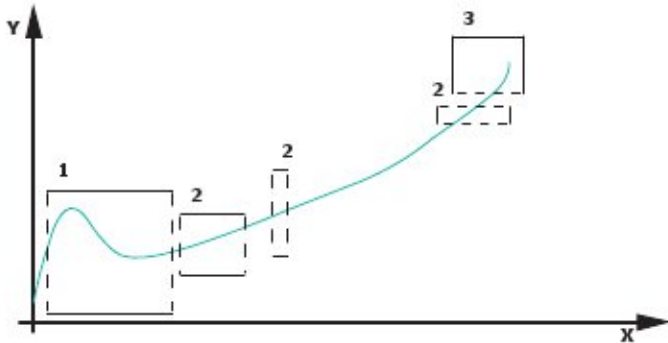

Insertion windows (1) are used with pressing-in and jointing processes where it is necessary to check that both parts join correctly. If they are not aligned, the force rises steeply and the curve leaves the insertion window by the upper edge. A real-time signal stops the press cycle and initiates the return stroke.

Pass-through windows (2) check the path of the force/displacement curve. The entry and exit sides can be freely defined. If a different window boundary is infringed, then this is detected as an error.

Block windows (3) monitor the force at the end stop. The curve must enter the window on the side defined and must not leave it again. Only one block window per program can be specified.

The processes measured, can be shown as a graphic or numeric display. For production runs, the system can be set to display the required processes on an external display via the serial interface.

We would be happy to provide you with more detailed documentation on the TPC system on request.

Software

TPC PLUS is a self-sufficient unit and can, in principle, be used without additional resources. The PC program, available as an accessory, allows external programming and back-up of measurement programs and configuration data and, in its measuring mode, also enables each press-in process to be documented.

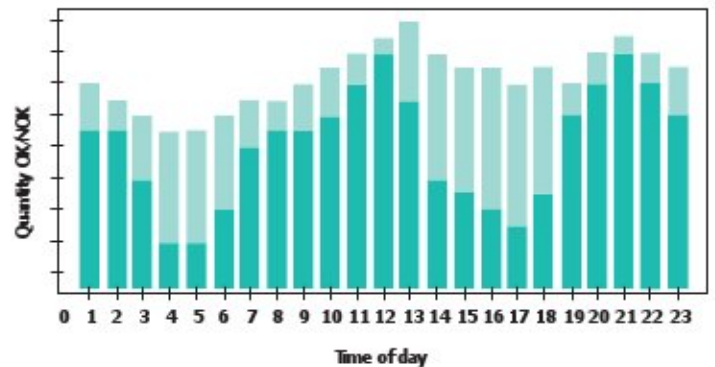

The software then also provides the data for statistical analyses.

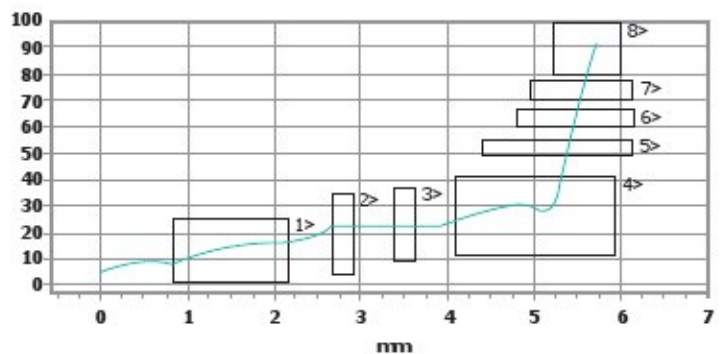

Displacement measuring by potentiometer	Total error	< 0.1 %
Force measuring by strain gage	Total error	< 0.5 % typ.
		ref. to 10 kN
		ref. to 20 kN
		ref. to 50 kN
Reduction of daylight due to	strain gage holder up to 10 kN	80 mm
	strain gage holder up to 20 kN DMS	91 mm
	strain gage holder up to 50 kN DMS	98 mm

ACCESSORIES AS AN ADDITION TO THE "STANDARD"

Press heads

Press heads are integrated as components in plant construction and in complex automation systems. For this reason, the heads for all presses can be obtained singly for individual installation. The need for complicated and expensive special designs is avoided, and costs are reduced thanks to the use of these ready-to-install kits.



Pneumatic toggle press head

Direct acting pneumatic press head

Tools and fixtures

Tools and fixtures for assembling, shaping, pressing, punching and cutting complement our range of presses.

For this purpose, standard tools are available for many applications. Over and above this, we design and manufacture customer-specific solutions.



Special models

In addition to the standard presses which are shown in this catalogue, special models and complete workstations can also be manufactured. This addresses today's requirements for flexible means of production which can be quickly adapted to suit the ever increasing diversity of models, smaller batch sizes and shorter production cycles.



Among other things presses also offer solutions for clean-room applications.

PNEUMATIC SLIDE TABLE

PST 130

PST pneumatic slide tables simplify manual and automatic insertion tasks and hence increase the cost-effectiveness of assembly processes.

The advantages:

- Insertion takes place outside the danger area.
- Pre-assembly of parts is possible without being impeded by the press.
- Versatile application possibilities for automation and delivery tasks.
- Precise positioning of workpieces.

Further quality features:

- Slide guide can be adjusted without play.
- Precision crossed roller guide with high loading capacity.
- End position damping at both ends.
- Can be installed transversely and longitudinally.
- Easily automated.

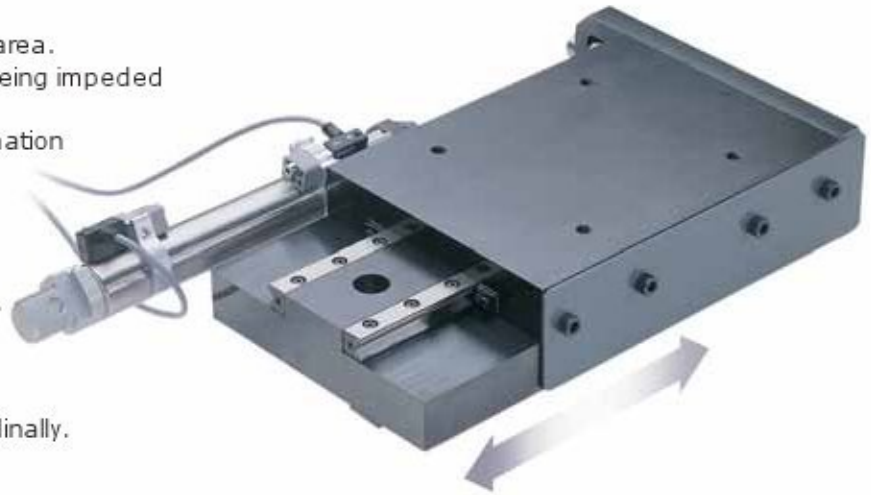

Application examples

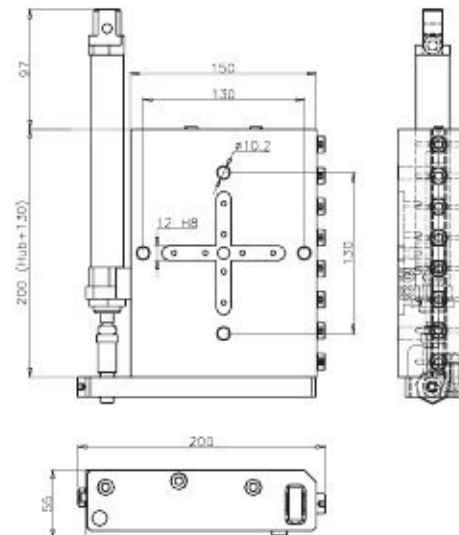

Typ	PST 130	suited for
Stroke*	130 mm	all pneumatic presses
Loading capacity	50 kN	up to 50 kN capacity

* other stroke lengths on request

Orbital riveting technology



Conveyor technology – Flexible assembly systems – Workpiece carriers – Transport systems



Presses and Rotary indexing tables

